



eSconce®
mini·eSconce™

Architectural Area Lighting

“to create, inspire and nurture excellence in each other”



ENERGY EFFICIENCY

The light sources employed in the eSconce family of fixtures are the most efficient sources commercially available today. The reflectors are designed to direct the illumination on the ground with no stray light which translates into wasted energy. The result is more light with less energy consumption.



LONGEVITY

AAL manufactures all its products to have a life span as long as the building or space they illuminate. The primary material used for all our products is aluminum to resist corrosion and the need for maintenance. Aluminum will not need the periodic refinishing required of steel products that will eventually rust and corrode. All our internal parts and fasteners are made of aluminum or stainless steel. The lamp enclosures are kept dust free and dry to prevent light degradation and maintain a high level of energy efficiency.



SUSTAINABILITY

AAL develops our products with recycling and resource management in mind. We recycle all incoming packaging materials. Our products are shipped in easy to recycle packaging materials. Our state of the art finishing system uses eco friendly cleansing and preparation chemicals that are harmless enough to send to the drain without further processing. Our powder coating process eliminates the release of volatile chemicals into the atmosphere. AAL makes the eSconce family, like all AAL products, with renewable materials such as aluminum and stainless steel.

Index

Applications 4-5
 eSconce Lamp Info 6
 mini•eSconce Lamp Info..... 7
 Fascia Options 8-9
 Universal Mounting..... 10
 eSconce Color Filters 11
 Applications 12-13
 Egress Lighting 14-15
 eSconce
 Installation 16
 Ordering Information 18-19
 Specifications 20
 Installation 21
 Photometry 22-23
 mini•eSconce
 Installation 24
 Photometry 25
 Ordering Information 26-27



AAL is a registered continuing education provider.

The eSconce® & mini eSconce™ are registered and protected by numerous patents granted by the United States Patent Office. U.S. Patents D426,665; D429,362; D429,020; D430,329

The eSconce is a registered trademark of Architectural Area Lighting.

© 2009 Architectural Area Lighting.
 Printed on recycled paper.



Exterior grade sconces with unmatched design flexibility
and lighting performance.

eSconce®



mini·eSconce™

The eSconce® luminaire is designed to convert an unwelcome but necessary object on the building's surface into an integral design element.



ES1-3 FPP

The eSconce series provides versatile, high performance lighting to meet the practical aspects of illuminating a site without scarring the building surface with an unattractive wall pack. Optional fascia panels and colored lenses transform the eSconce series into a decorative accent while retaining the benefits of its high performance illumination.



ME2 FPP



ES2-4 LAG



ES3-CFX FPC



ES1-4

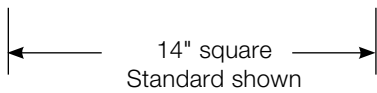

ES1 - uplight or downlight

ES2 - uplight + downlight

Lamps

- Metal Halide - 50 to 150 watts, ED-17 and T-6 lamps
- High Pressure Sodium - 50 to 150 watts, ED-17 lamps

ES3 - uplight, downlight, or uplight + downlight

Lamps

- Compact Fluorescent: 1 or 2 PLT lamps 26, 32 or 42 watt
- Light Emitting Diode (LED): 36 LED array or
36 LED array primary
18 LED array secondary



Optical Systems

The ES1 and ES2 are available with four precise optical systems for use with metal halide or high pressure sodium lamps. The T-6 ceramic metal halide lamps can be specified to ensure color accuracy and consistency. The ES3 utilizes 26, 32, or 42 watt compact fluorescent lamps with a Type 3 reflector, or 36 LED array (36/18 for uplight/downlight).

Type 2 Reflector
Wide, Shallow beam

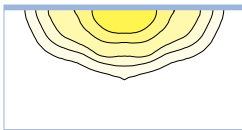

Type 4 Reflector
Forward Throw Beam

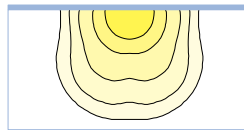

Type 3 Reflector
Medium Throw Beam

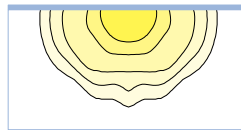

Column Accent
Narrow Short Beam

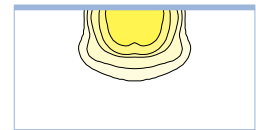

Optional LDL lens

The lightly diffused lens reduces the overall brightness of the fixture reflector. This lens eliminates discomfort glare when using HID lamps or LEDs at low mounting heights or when the viewing angle allows a direct line of sight into the reflector.



mini•eSconce™

ME1 - one lamp uplight and/or downlight

ME2 - two lamps uplight and/or downlight

Lamps

- Compact Fluorescent: 1 or 2 PL-C 13 watt lamps

ME-LED

- Light Emitting Diodes: 5 watt array

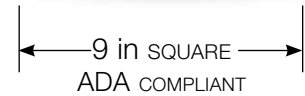

The standard mini•eSconce has a fully luminous front cover made of impact resistant opal acrylic. The soft surface illumination increases the vertical illumination for hallways and entrances. The optional painted aluminum panel mimics the design of the larger eSconce.



ME2
standard luminous fascia



ME2-9S0
optional fascia overlay panel



ME2-Blank
optional fascia overlay panel

An Optional Palette of



Standard mini•eSconce with fully luminous fascia



mini•eSconce painted aluminum fascia with center window
9S0 option



mini•eSconce painted aluminum blank fascia
BLN option



Standard eSconce with a luminous center lens



Internal Gel Filter
GFH option



Edge lit acrylic ribs
LAG option

eSconce with Center Overlay Panel

PERMANENTLY ATTACHED AND PAINTED TO MATCH THE FIXTURE



Perforated
SMP option



4-Square
SM4 option



Blank Front
SMB option

Fascias, Colors and Finishes

Full overlay panels are available options in painted aluminum, stainless steel or natural copper. The panels are permanently attached to the standard fixture door with no visible fasteners for a clean, finished appearance.

Full Overlay Panel with Perforated Center

FOR THE **eSCONCE** AND **MINI•eSCONCE**



Perforated Painted Finish
FPP option



Perforated Stainless Steel
FPS option



Perforated Natural Copper
FPC option

Full Overlay Panel with 4 Squares

FOR THE **eSCONCE** AND **MINI•eSCONCE**



4-Square Painted Finish
F4P option



4-Square Stainless Steel
F4S option



4-Square Natural Copper
F4C option

eSconce[®] mini•eSconce[™]

Universal Mounting



No special ordering is required to use the eSconce or mini•eSconce in the uplight or downlight position. Both are wet location listed in either the up or down position to accommodate changes in the field during construction.

Uplight and Downlight



The ES2 has an indirect component for soft secondary illumination. The universal mount design of the eSconce allows the indirect component to be oriented either in the up or down position. A molded glass spread lens casts an even, streak-free glow on the wall.



All mini•eSconce models can be converted to an uplight and downlight configuration by removing an internal cover plate. The ME2 shown has the optional aluminum fascia panel to mimic the appearance of the standard eSconce luminaire.

eSconce®

Luminous Accents



Add Color to the Front Fascia Lens

An optional internal gel filter holder can be added to the eSconce to add color to the luminous front lens.

The holder can be field installed, even after installation for added flexibility.

The gel filter can also be easily changed to a different color. Gel filters are readily available in a wide variety of colors and are inexpensive to use.



Add Edge Lit Acrylic Ribs for a Neon Appearance

The optional luminous grill assembly fits over the front lens to add visual interest day or night. This option can be combined with the gel filter option to add color to the luminous ribs.



Interior



The versatility of the eSconce® luminaire allows you to carry the exterior lighting theme into the interior setting. With multiple options, the eSconce utilizes lighting as a design element to the interior structure.

ES1-2



ES1-W F4P

Exterior



ES2-4 FPS

Aesthetically designed for the public side, yet rugged and cost effective for the business side.



ME2-9SO



ES1-2



ES2-3 SM4 LDL



The eSconce's emergency lighting options illuminate corridors, building entrances and exterior passages for added safety and security. Most local and national building codes now require a lighted path to a designated safe area away from the building, not just to an entrance or exit door.



Egress

The eSconce® eliminates the need for secondary fixtures used as emergency egress lighting. All emergency lighting options are installed in the housing, thereby eliminating external compartments or secondary fixtures which result in extra material and labor costs.

Two eSconce egress options are available for use with metal halide or high pressure sodium HID lamps. Not available with LED.



ES1-2 LAG

The ES3 eSconce and the mini•eSconce use compact fluorescent lamps and LEDs that restart instantly after a momentary power loss.

For applications requiring an emergency backup power supply, the ES3 compact fluorescent eSconce can be equipped with the BBU option.

- **BBU** – Battery backup powers a compact fluorescent lamp for up to 90 minutes during a power failure. Output of the 26 watt lamp will be 450 lumens. Output of the 32 watt lamp will be 575 lumens. Output of the 42 watt lamp will be 750 lumens. Not available with HID or LED.



eSconce®

Easy Installation



1 Secure the cast back plate to a standard junction box. A quick disconnect plug is then wired to the electric power leads.



2 Plug the disconnect into the fixture. Hang the fixture onto the mounting plate. To mount as an upright, simply turn the fixture upside down!



3 Tighten the two captive bolts to secure the fixture to the mounting plate.

Optional Surface Mounted Conduit Box



SCB

Surface Conduit Box

The low profile design keeps the fixture visually anchored to the wall. The box is concealed behind the fascia of the fixture. The surface conduit box can be installed prior to the fixture installation.



eSconce®

Design Quality

- Precision die-cast aluminum construction.
- All internal brackets and reflector components are aluminum.
- All gaskets are one-piece memory retentive molded silicone to prevent degradation resulting from heat or exposure to the elements.
- All internal and external hardware is stainless steel.

No tools are required to access the lamp - just flip forward the spring loaded latch. The ballast module can be removed by loosening two screws and lifting off the module. The molded, tempered glass lens is crowned to allow proper water run-off when used in an up orientation.



The eSconce luminaire is completely sealed from the elements, including insects and dirt that can enter the fixture through the conduit. The back of the eSconce has a silicone plug to prevent contamination from ever entering the fixture.



eSconce® Ordering Information

1	2	3	4	5
FIXTURE	LAMP/BALLAST	COLOR	OPTIONS	FASCIA OPTIONS
ES1-2	50MH	BLK	QRS	LAG

1. FIXTURE

ES1	UPLIGHT OR DOWNLIGHT - HID – BALLAST NOT INCLUDED
ES1-2	Type 2 distribution
ES1-3	Type 3 distribution
ES1-4	Type 4 distribution
ES1-W	Column lighter-narrow beam distribution
ES2	UPLIGHT AND DOWNLIGHT - HID – BALLAST NOT INCLUDED
ES2-2	Type 2 distribution, 90% primary - 10% secondary light ratio
ES2-3	Type 3 distribution, 90% primary - 10% secondary light ratio
ES2-4	Type 4 distribution, 90% primary - 10% secondary light ratio
ES3	COMPACT FLUORESCENT – BALLAST INCLUDED
ES3-CF1	Up or down light, one 26, 32 or 42 watt, 4 pin lamp. Specify wattage. -18°C min start temp. 120 thru 277 volt.
ES3-CF2	Up or down light, two 26, 32 or 42 watt, 4 pin lamps. Specify wattage. -18°C min start temp. 120 thru 277 volt.
ES3-CFX	Up and down light, two 26, 32 or 42 watt, 60% - 40% light distribution. Specify wattage. -18°C min start temp. 120 thru 277 volt.
ES3	LIGHT EMITTING DIODE (LED) – DRIVER INCLUDED
ES3-36LED-WW	Up or down light, 36 light emitting diode array (37 watt). Warm white (3500K). 120 thru 277 volt.
ES3-36LED-BW	Up or down light, 36 light emitting diode array (37 watt). Bright white (5100K). 120 thru 277 volt.
ES3-54LED-WWX	Up and down light. Primary output 36 LEDs (37 watt). Secondary output 18 LEDs (18 watt). Warm white (3500K). 120 thru 277 volt. 60% primary - 40% secondary light distribution.
ES3-54LED-BWX	Up and down light. Primary output 36 LEDs (37 watt). Secondary output 18 LEDs (18 watt). Bright white (5100K). 120 thru 277 volt. 60% primary - 40% secondary light distribution.

2. LAMP/BALLAST

ES1 OR ES2

39MHT6	39 watt metal halide, 120/277 volt ballast. Use G12 base, T6 ceramic lamp.
50MH	50 watt metal halide, 120/277 volt ballast. Use medium base, ED-17 lamp.
70MH	70 watt metal halide, 120/208/240/277 volt ballast. Use medium base, ED-17 lamp.
70MHT6	70 watt metal halide 120/277/347 volt ballast. Use G12 base, T6 ceramic lamp.
100MH	100 watt metal halide, 120/208/240/277 volt ballast. Use medium base, ED-17 lamp.
150PSMH	Pulse start 150 watt metal halide, 120/208/240/277 volt ballast. Use medium base, ED-17 lamp.
150PSMHT6	Pulse start 150 watt metal halide 120/277 volt ballast. Use G12 base, T6 ceramic lamp.
50HPS	50 watt high pressure sodium, 120/277 volt ballast. Use medium base, ED-17 lamp.
70HPS	70 watt high pressure sodium, 120/208/240/277 volt ballast. Use medium base, ED-17 lamp.
100HPS	100 watt high pressure sodium, 120/208/240/277 volt ballast. Use medium base, ED-17 lamp.
150HPS	150 watt high pressure sodium, 120/208/240/277 volt ballast. Use medium base, ED-17 lamp.

*All ballasts are factory wired for 277 volts, unless specified. Lamps not included, except LED option.
All applicable ballasts are EISA compliant.*

3. COLORS

All standard and premium AAL colors available.

For RAL and custom colors, please submit a 4-digit RAL number or color chip for custom colors.

4. OPTIONS

QRS	Restrike controller and T-4 mini-can socket. (Lamp wattage not to exceed ballast wattage). Not available with LED.
QL	Socket for T-4 mini-can lamp, field wired to a separate circuit. (Lamp wattage not to exceed ballast wattage). Not available with LED.
SCB	Surface conduit box. 1/2" NPT inlets on each side. Gasketed cover. Comes standard in white.
LDL	Lightly diffused glass lens to conceal the reflector and decrease visual brightness. Primary lens only.
BBU	Battery backup powers a compact fluorescent lamp for up to 90 minutes during a power failure. Output of the 26 watt lamp will be 450 lumens. Output of the 32 watt lamp will be 575 lumens. Output of the 42 watt lamp will be 750 lumens. Not available with HID or LED.
347	120/240/347 volt ballast for HID lamp/ballast except the 50 HPS which is a 120/347 volt ballast. Not available with LED.
GFH	Gel filter holder to add color to the luminous front lens. The holder can be field installed. Filter size is 9.5"/240mm x 1.75"/50mm. A template of the filter size and shape is provided. The filters are not supplied or installed by AAL. Standard gel high temperature filters are available from Lee Filters (Burbank CA), ROSCO (Stanford CT) or others. Use high temperature filters for longer life.
PC12	120 volt swivel type photocell (specify voltage).
PC27	208-277 volt swivel type photocell (specify voltage).

5. FASCIA OPTIONS

Luminous Acrylic Rib

Edge lit acrylic grill assembly fits over the front lens. Can be combined with the gel filter holder option (GFH) to add color to the edges of the acrylic ribs.

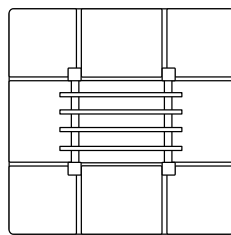

LAG

Metal Finishes On Full Panel Fascias

The stainless steel fascia panels have a #4 brushed finish with horizontal grain direction.

The copper fascia panels will patina over time.

SMALL CENTER PANEL (PAINTED THE SAME COLOR AS THE FIXTURE)

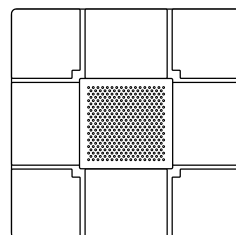

SMP
PERFORATED

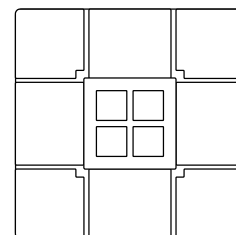

SM4
4 SQUARES

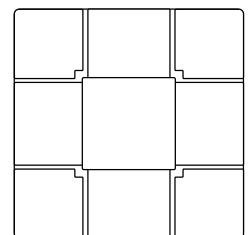

SMB
BLANK COVER

FULL PANEL WITH A PERFORATED CENTER

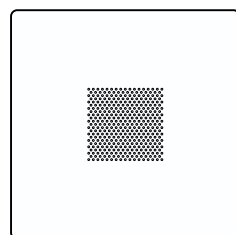

FPP
PAINTED FINISH

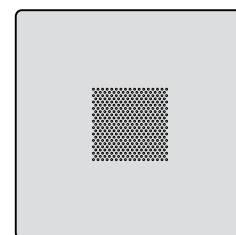

FPS
BRUSHED STAINLESS
STEEL

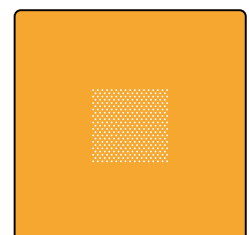

FPC
NATURAL COPPER

FULL PANEL WITH A 4 SQUARE CENTER

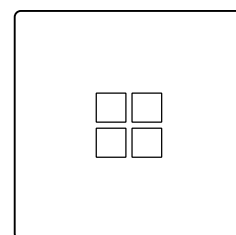

F4P
PAINTED FINISH

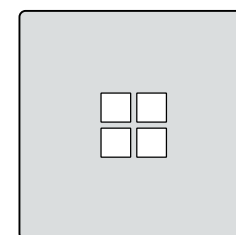

F4S
BRUSHED STAINLESS
STEEL



F4C
NATURAL COPPER

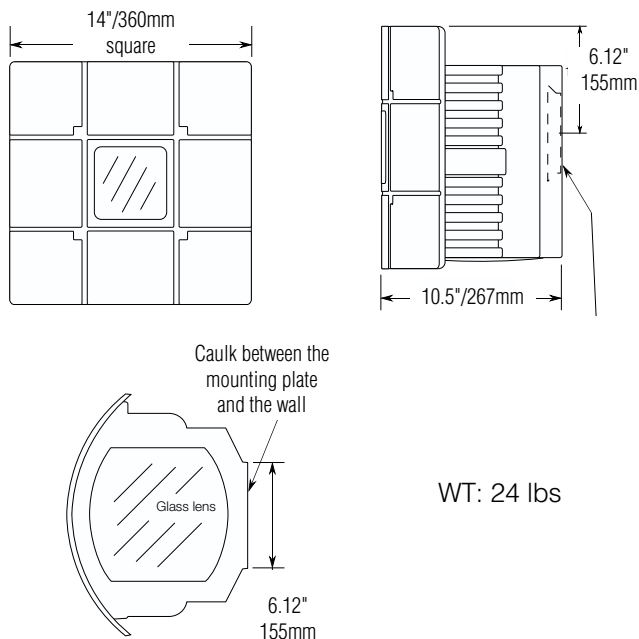

HOUSING

The fixture housing is one piece die cast aluminum. The front door is die cast aluminum, hinged and secured with a self tensioning latch for relamping and internal access. The front glass element is etched, tempered glass. The front lens is internally illuminated when the fixture is energized. The main lens for the reflector is molded tempered glass with a crowned shape to shed water when the fixture is oriented as an uplight. The secondary lens for uplight (or downlight) is a molded, prismatic glass refractor lens to evenly illuminate the wall.

The front door is sealed with a one-piece memory retentive, molded silicone gasket. The rear electrical access has a molded silicone plug to completely seal the fixture from insects or dirt emanating from the electrical box or conduit. All internal and external hardware is stainless steel.

OPTICAL ASSEMBLY

The reflector module is composed of faceted, semi specular anodized aluminum panels rigidly attached in an aluminum module finished in high reflectance white. The reflector module is easily removed by loosening four screws and lifting it out. The ES2, HID uplight + downlight version includes a second reflector assembly attached to the door which directs the light energy to the refractor lens used for the secondary light output. The ES3, compact fluorescent and LED uplight + downlight versions have a second reflector assembly used to direct light through the refractor lens.

ELECTRICAL

The ballast is mounted on a prewired module with a quick disconnect plug and removed by loosening two captive screws. HID ballasts are high power factor, rated for -30°C starting. Sockets are medium base, pulse rated porcelain. Compact fluorescent sockets for a 26, 32 or 42 watt lamp are 4 pin, GX24q-3,4, with an electronic ballast, -18°C starting. The CF ballast and LED driver will accept an input voltage of 120 thru 277 volts.

FINISH

Fixture finish consists of a five stage pretreatment regimen with a polymer primer sealer, oven dry off and top coated with a thermoset super TGIC polyester powder coat finish. The finish shall meet the AAMA 605.2 performance specification which includes passing a 3000 hour salt spray test for corrosion resistance.

INSTALLATION

To install the fixture, the die cast wall plate is secured to a octagonal j-box and wired to the power circuit. The fixture is plugged into a quick disconnect and then hooked onto the wall plate. Two captive screws are then tightened to secure the fixture to the wall plate.

EISA COMPLIANCE

AAL is committed to complying with U.S. EISA requirements. All applicable products manufactured for sale in the United States after January 1, 2009, meet EISA requirements.

CERTIFICATION

The fixture is listed with ETL for outdoor, wet location use, in both an up and down orientation, UL1598 and Canadian CSA Std. C22.2 NO.250. IP=65

WARRANTY

Fixture is warranted for three years. Ballast components carry the ballast manufacturer's limited warranty. Any unauthorized return, repair, replacement or modification of the Product(s) shall void this warranty. This warranty applies only to the use of the Product(s) as intended by AAL and does not cover any misapplication or misuse of said Product(s), or installation in hazardous or corrosive environments. Contact AAL for complete warranty language, exceptions, and limitations.

Standard Mounting

1. Attach the back plate to a standard octagonal box or the surface with the appropriate fastener.
2. Caulk between the back plate and wall with a recommended caulk or sealant.
3. Wire the supplied quick disconnect to the electric power leads. All eSconce fixtures are factory wired for 277 volts, unless specified. For other voltages, use an available capped ballast lead(s) for the desired voltage. Attach the new lead to the disconnect plug on the fixture and cap the 277 lead from the ballast.
4. Plug together the fixture and power lead disconnects.
5. Hang the fixture onto the mounting plate. Fixture can be oriented with the main lens up or down.
6. Tighten the two captive, 3/8-16 hex (allen) head bolts to secure the fixture to the mounting plate.

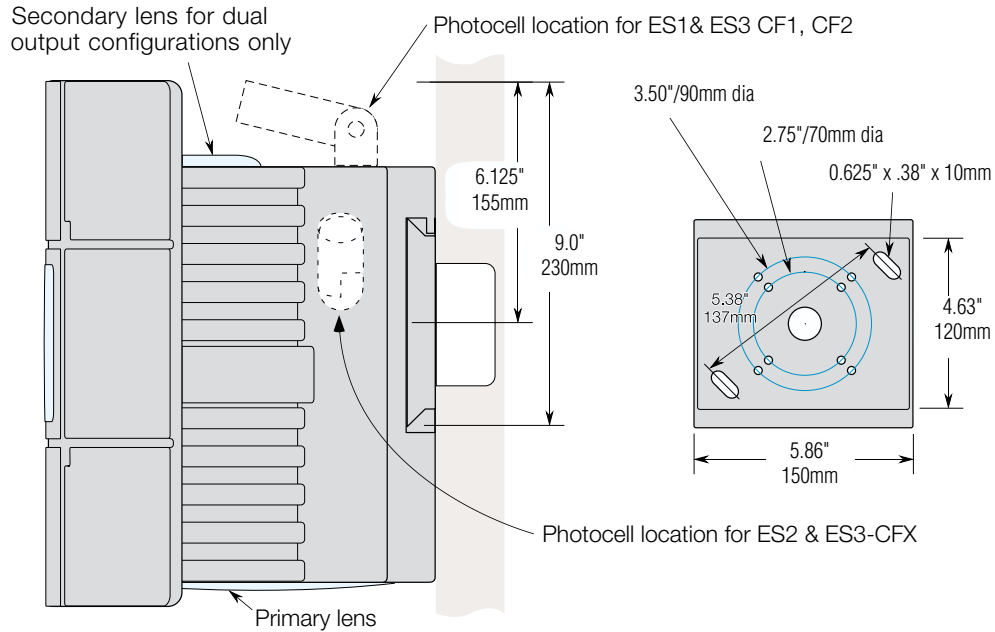

Mounting the Optional Surface Conduit Box

Attach the SCB to the wall prior to installing the fixture. A gasketed cover is included. The SCB is finished in white.

Note:
Mounting hardware by others.

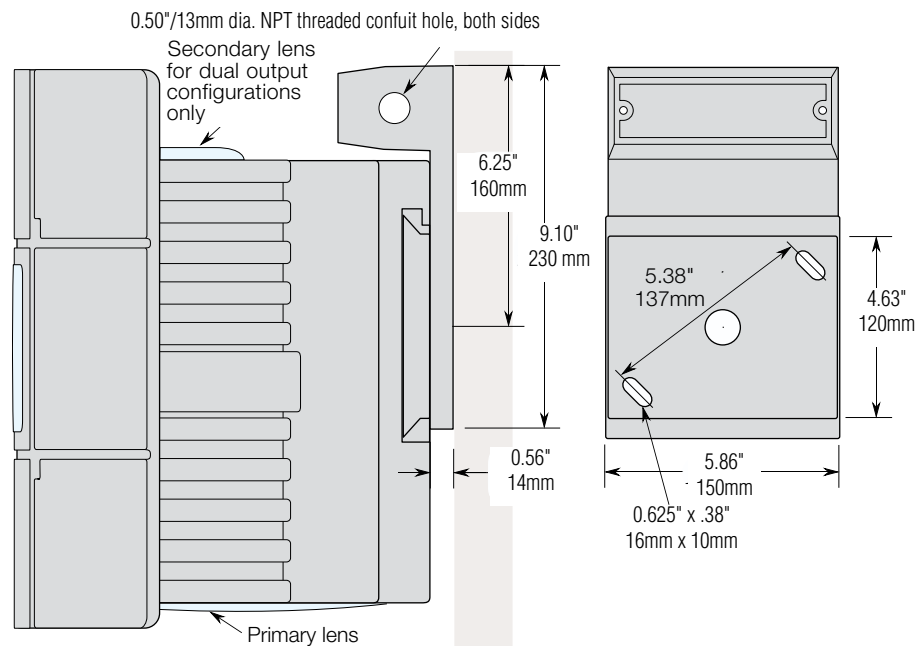

The values shown are in initial footcandles. Discount values to account for light losses due to voltage, temperature and atmospheric variations which affect light output.

To substitute another lamp in either chart, multiply the chart values by the lamp conversion factor. Mounting height is to the lamp center. All testing is performed by a certified independent laboratory.

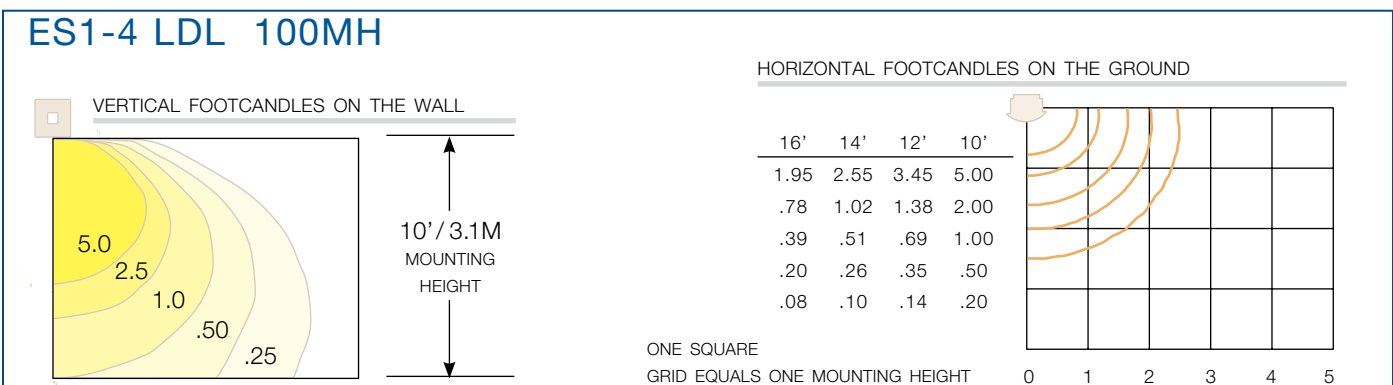
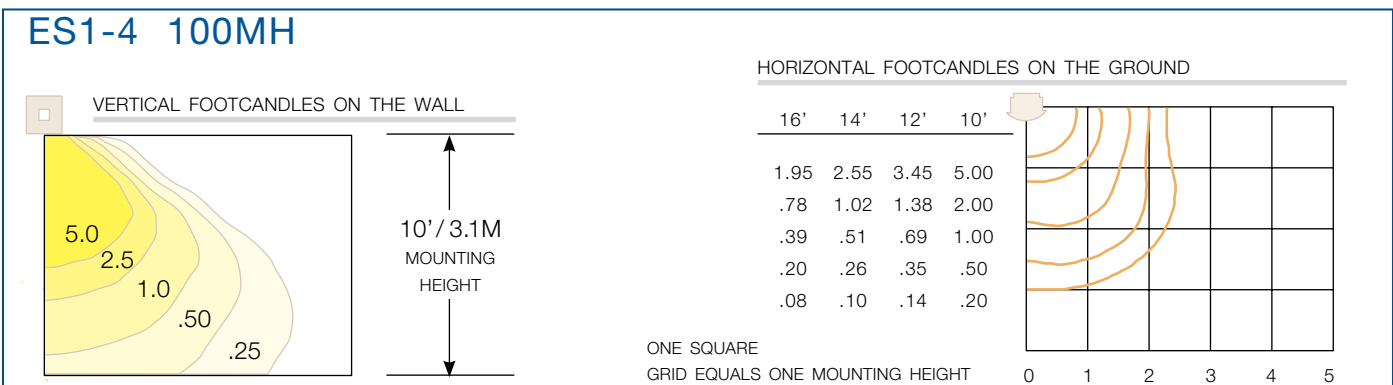
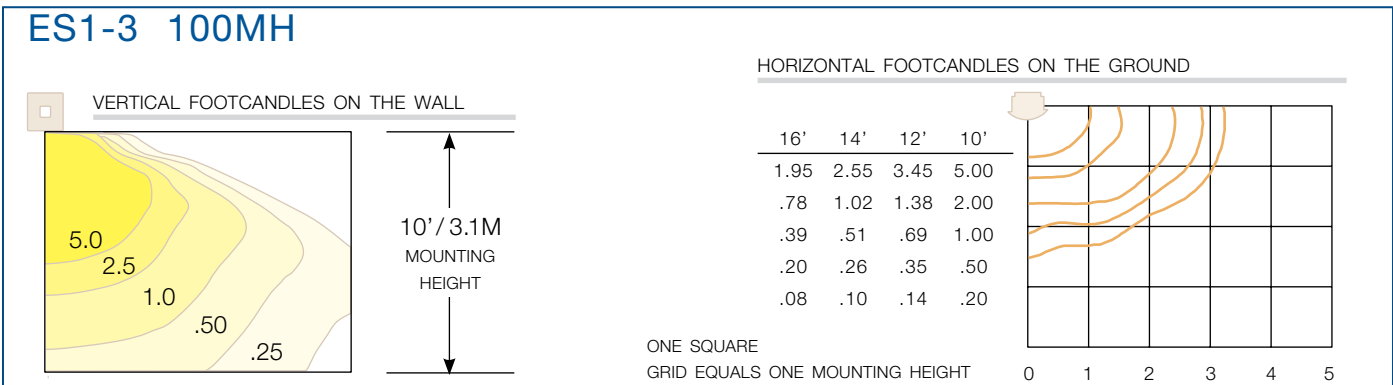
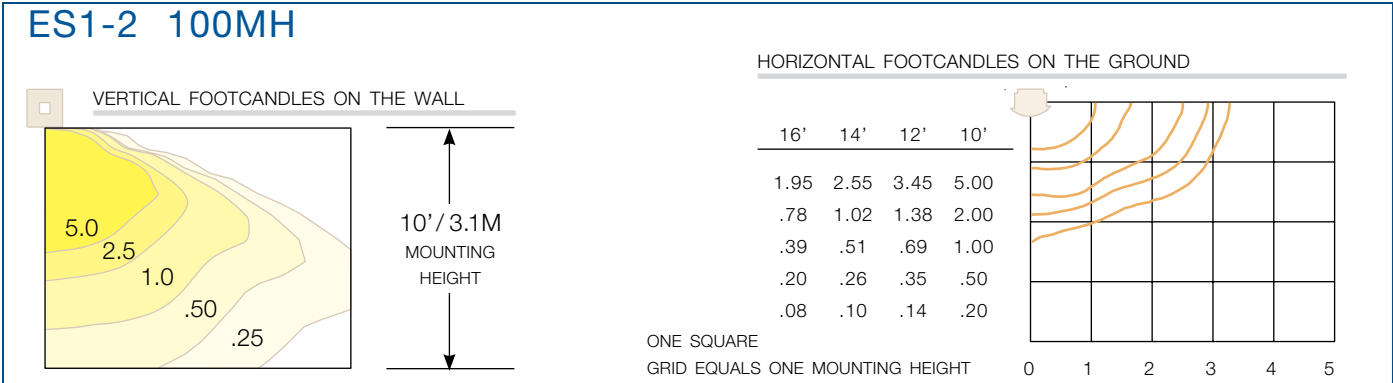

LAMP TYPE		CONVERSION FACTOR
50 MH, CLEAR ED-17	3200 LUMENS	.38
70 MH, CLEAR ED-17	5200 LUMENS	.61
100 MH, CLEAR ED-17	8500 LUMENS	1.00
150 PSMH, CLEAR ED-17	12,500 LUMENS	1.47

NOTE: If using a lamp with different lumen output than listed above, consult AAL for conversion factors.

LAMP TYPE		CONVERSION FACTOR
50 HPS, CLEAR ED-17	3600 LUMENS	.42
70 HPS, CLEAR ED-17	6400 LUMENS	.75
100 HPS, CLEAR ED-17	9500 LUMENS	1.12
150 HPS, CLEAR ED-17	16,000 LUMENS	1.88
42 CF COMPACT FLUORESCENT,	3200 LUMENS	.38

NOTE: If using a lamp with different lumen output than listed above, consult AAL for conversion factor

ES1-W 100MH

VERTICAL FOOTCANDLES ON THE WALL

10' / 3.1M MOUNTING HEIGHT

HORIZONTAL FOOTCANDLES ON THE GROUND

16'	14'	12'	10'
1.95	2.55	3.45	5.00
.78	1.02	1.38	2.00
.39	.51	.69	1.00
.20	.26	.35	.50
.08	.10	.14	.20

ONE SQUARE GRID EQUALS ONE MOUNTING HEIGHT

ES2-2 100MH

VERTICAL FOOTCANDLES ON THE WALL

10' / 3.1M MOUNTING HEIGHT

HORIZONTAL FOOTCANDLES ON THE GROUND

16'	14'	12'	10'
1.95	2.55	3.45	5.00
.78	1.02	1.38	2.00
.39	.51	.69	1.00
.20	.26	.35	.50
.08	.10	.14	.20

ONE SQUARE GRID EQUALS ONE MOUNTING HEIGHT

ES2-4 100MH

VERTICAL FOOTCANDLES ON THE WALL

10' / 3.1M MOUNTING HEIGHT

HORIZONTAL FOOTCANDLES ON THE GROUND

16'	14'	12'	10'
1.95	2.55	3.45	5.00
.78	1.02	1.38	2.00
.39	.51	.69	1.00
.20	.26	.35	.50
.08	.10	.14	.20

ONE SQUARE GRID EQUALS ONE MOUNTING HEIGHT

ES3-CFX 42PLT

VERTICAL FOOTCANDLES ON THE WALL

10' / 3.1M MOUNTING HEIGHT

HORIZONTAL FOOTCANDLES ON THE GROUND

16'	14'	12'	10'
1.95	2.55	3.45	5.00
.78	1.02	1.38	2.00
.39	.51	.69	1.00
.20	.26	.35	.50

ONE SQUARE GRID EQUALS ONE MOUNTING HEIGHT

mini•eSconce™

Design Quality



Easy Installation



Attach the mounting plate to the wall or j-box.



Attach the housing to the mounting plate.



Connect the wire leads and push the silicone plug into the back of the housing.



Attach the lamp module to the housing and install the cover.

mini•eSconce™ Ordering Information

1	2	3
FIXTURE	COLOR	FASCIA PANEL (OPTIONAL)
ME-LED	BLK	FPP

1. FIXTURE

UPLIGHT • DOWNLIGHT • UPLIGHT + DOWNLIGHT

ME1 One lamp, 13 watt PL-C, 4 pin, twin tube lamp.

ME2 Two lamp, 13 watt PL-C, 4 pin, twin tube lamps. (One ballast supplied for both lamps)

Ballasts are electronic, 120 through 277 volts. Lamps not included.

ME-3LED-WW 3LED array (5 watt). Warm white (3500K). 120 thru 277 volt.

ME-3LED-BW 3LED array (5 watt). Bright white (5100K). 120 thru 277 volt.

2. COLOR

All standard and premium AAL colors available.

For RAL and custom colors, please submit a 4-digit RAL number or color chip for custom colors.

3. FASCIA PANELS

9SO 9 Square fascia panel with open center - painted aluminum

BLN 9 Square blank fascia panel - painted aluminum

FPP Perforated center fascia panel - painted aluminum

FPS Perforated center fascia panel - brushed # 4 stainless steel

FPC Perforated center fascia panel - natural copper

F4P 4 squares center fascia panel - painted aluminum

F4S 4 squares center fascia panel - brushed # 4 stainless steel

F4C 4 squares center fascia panel - natural copper

The fascia panels are attached by sliding the panel over the cover and locking down four corner tabs.

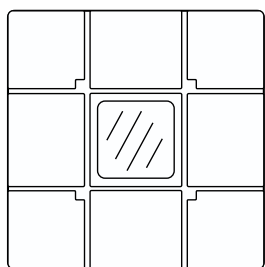

9SO

9 square open center
painted aluminum

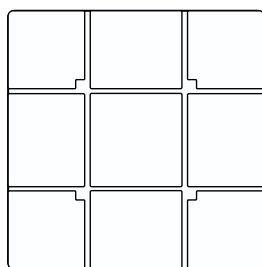

BLN

9 square blank
painted aluminum

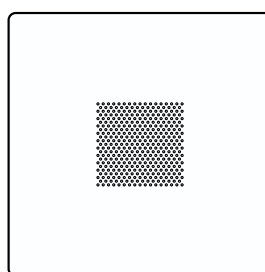

perforated center

FPP - painted aluminum
FPS - stainless steel
FPC - copper

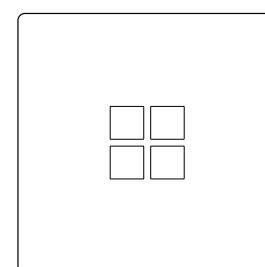

4 squares

F4P - painted aluminum
F4S - stainless steel
F4C - copper

mini•eSconce™ Specifications

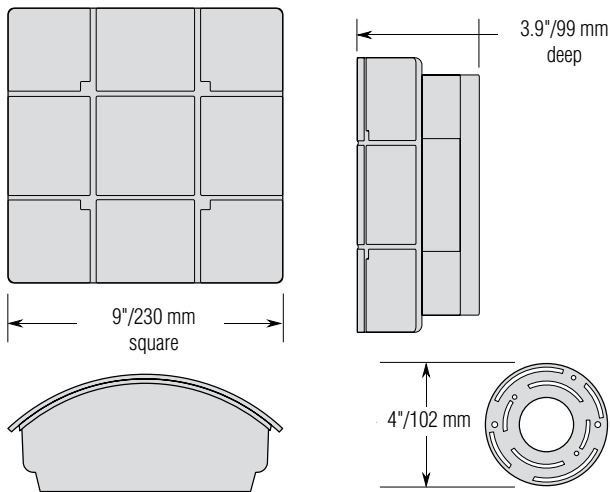

WT: 2 lbs

HOUSING

The fixture housing is one piece injection molded acrylic with a lightly diffused finish. The front cover is opal, semi translucent injection molded acrylic. The cover is secured with two self tensioning latches for relamping and internal access. The front cover is sealed with a one-piece memory retentive molded silicone gasket. The rear electrical access has a molded silicone plug to completely seal the fixture from insects or dirt emanating from the electrical box or conduit. All internal and external hardware is stainless steel.

REFLECTOR TRAY

The reflector tray is formed aluminum finished in high reflectance white. The aluminum block off plate is removable for converting the fixture to an uplight or downlight configuration.

ELECTRICAL

The ballast is mounted on the reflector tray. The ballast is electronic for use with PL-C lamps; 4 pin, G24q-1 sockets. The ballast will accept an input voltage of 120 through 277 volts. The ME-LED shall use a 3LED module (5 watt) for 120 volt input.

FINISH

The finish for the optional aluminum fascia covers consists of a five stage pretreatment regimen with a polymer primer sealer, oven dry off and top coated with a thermoset super TGIC polyester powder coat finish. The finish shall meet the AAMA 605.2 performance specification which includes passing a 3000 hour salt spray test for corrosion resistance.

INSTALLATION

To install the fixture, the housing is secured to an octagonal j-box and wired to the power circuit.

EISA COMPLIANCE

AAL is committed to complying with U.S. EISA requirements. All applicable products manufactured for sale in the United States after January 1, 2009, meet EISA requirements.

CERTIFICATION

The fixture is listed with ETL for outdoor, wet location use, UL1598 and Canadian CSA Std. C22.2 NO.250. IP=54

WARRANTY

Fixture is warranted for three years. Ballast components carry the ballast manufacturer's limited warranty. Any unauthorized return, repair, replacement or modification of the Product(s) shall void this warranty. This warranty applies only to the use of the Product(s) as intended by AAL and does not cover any misapplication or misuse of said Product(s), or installation in hazardous or corrosive environments. Contact AAL for complete warranty language, exceptions, and limitations.

mini•eSconce™

Photometry

ME1 1-13 watt PL-C lamp, shown as an uplight & downlight

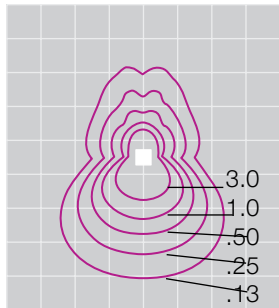

VERTICAL FOOTCANDLES
ON THE WALL

8'/2.5M MOUNTING HEIGHT
EACH SQUARE EQUALS 2'/.61M

HORIZONTAL FOOTCANDLES ON
THE GROUND

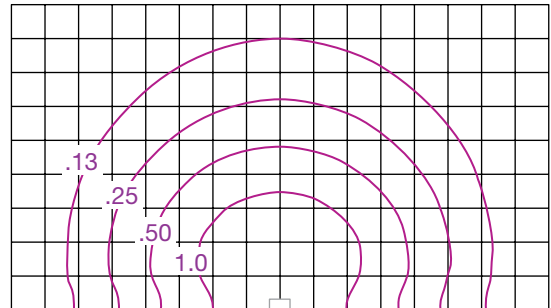

ME2 2-13 watt PL-C lamps, uplight & downlight

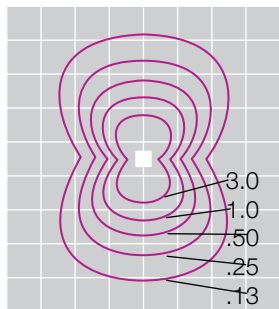

VERTICAL FOOTCANDLES
ON THE WALL

8'/2.5M MOUNTING HEIGHT
EACH SQUARE EQUALS 2'/.61M

HORIZONTAL FOOTCANDLES ON
THE GROUND

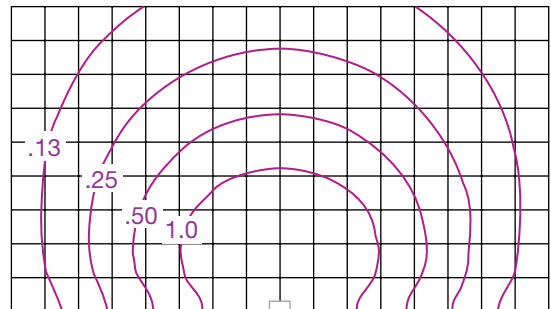

ME2-9SO 2-13 watt PL-C lamps, 9 square fascia panel with center opening, uplight & downlight

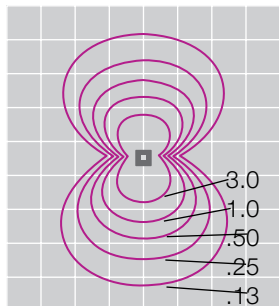

VERTICAL FOOTCANDLES
ON THE WALL

8'/2.5M MOUNTING HEIGHT
EACH SQUARE EQUALS 2'/.61M

HORIZONTAL FOOTCANDLES ON
THE GROUND

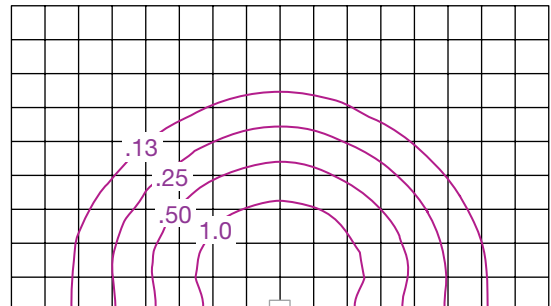

ME2-9SOcp 2-13 watt PL-C lamps, 9 square fascia panel with center opening, cover plate on top

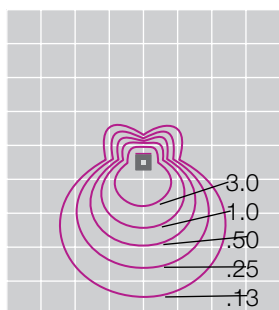

VERTICAL FOOTCANDLES
ON THE WALL

8'/2.5M MOUNTING HEIGHT
EACH SQUARE EQUALS 2'/.61M

HORIZONTAL FOOTCANDLES ON
THE GROUND

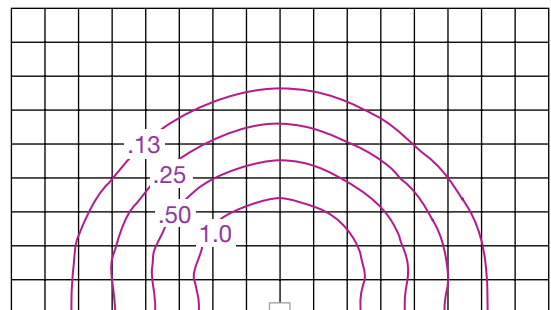

eSconce® Series



Architectural Area Lighting
16555 East Gale Ave. | City of Industry | CA 91745
T 626.968.5666 | F 626.369.2695 | www.aal.net/aal/esme110.html