

SLA 10

Slips over 4" pole
Weight: 9 LBS. EPA: 1.09

The arm shall be of one piece unitized aluminum construction, fully welded and assembled. The slip fitter shall be cast aluminum with an internal wireway and pole stop. The pole cap shall be cast aluminum. The arm shall be prewired with a quick connector for easy installation.

The arm shall have a cast aluminum fitter welded to the top of the arm(s) for attaching the fixture. The fixture shall be mounted with three stainless steel bolts through the top of the arm fitter into the fixture. The attachment point shall have a silicone pad for sealing the fixture to arm connection.

The arm shall slip over a 4"/100mm diameter pole or tenon. The cast aluminum slip fitter shall have six stainless steel cup point set screws for securing the arm to the pole or tenon.

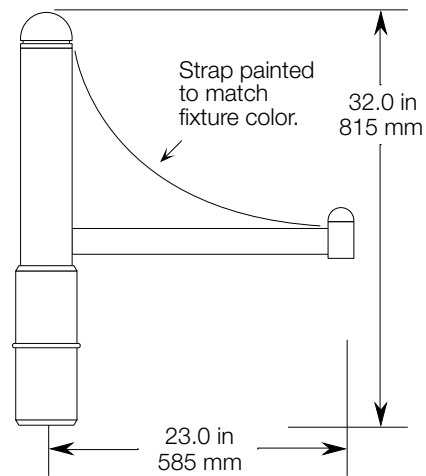

SOLD TO	PO #	JOB NAME
/	/	/

APPROVALS

Architectural Area Lighting

16555 East Gale Ave. | City of Industry | CA 91745
P 626.968.5666 | F 626.369.2695 | www.aal.net
Design patents, Copyright © 2010 Rev 01/2010

SLA 10-2

Twin arms, slips over 4" pole

Weight: 16 LBS. EPA: 1.47

The arms shall be of one piece unitized aluminum construction, fully welded and assembled. The slip fitter shall be cast aluminum with an internal wireway and pole stop. The pole cap shall be cast aluminum. The arm shall be prewired with a quick connector for easy installation.

The arms shall have a cast aluminum fitter welded to the top of the arm(s) for attaching the fixture. The fixture shall be mounted with three stainless steel bolts through the top of the arm fitter into the fixture. The attachment point shall have a silicone pad for sealing the fixture to arm connection.

The arm shall slip over a 4"/100mm diameter pole or tenon. The cast aluminum slip fitter shall have six stainless steel cup point set screws for securing the arm to the pole or tenon.

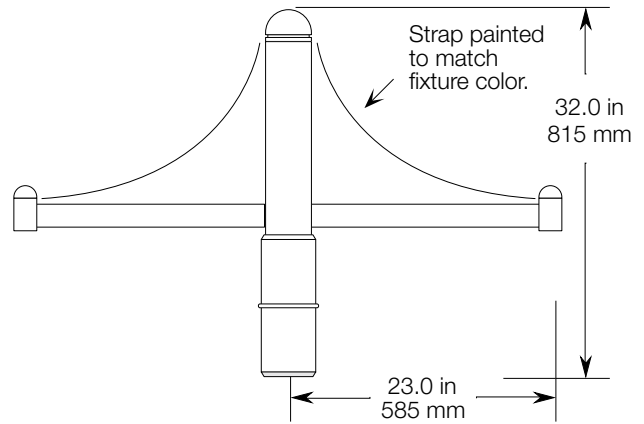

SOLD TO	PO #	JOB NAME
/	/	/

APPROVALS

Architectural Area Lighting

16555 East Gale Ave. | City of Industry | CA 91745
 P 626.968.5666 | F 626.369.2695 | www.aal.net
 Design patents, Copyright © 2010 Rev 01/2010