

1	2	3	4	5	6	7			8
LUMINAIRE	HOOD STYLE	LENS/ELEMENT	LAMP/BALLAST	HOOD FINISH	COLOR	OPTIONS			MOUNTING



SPECTRA
SMALL SCALE HOUSING



SP2



SPECTRA FAMILY OF FIXTURES



SP1

SP2

SP10

SPB

Features

- Four hood styles and four lens elements to configure a look of harmony with your architecture
- Symmetric or asymmetric distribution
- Post-top, wall mount arm, or pole mount arm options
- Tool-less access with captive fastener
- Adaptable appearance is perfect for contemporary or traditional installations
- Stainless steel struts
- EISA compliant
- IP65 rated
- Powder coat finish in 13 standard colors with a polymer primer sealer

JOB INFORMATION
TYPE
JOB NAME
LAMP (BY OTHERS)
CUSTOMER
DATE
<i>Consult factory for any custom/modified products</i>
APPROVALS

1	2	3	4	5	6	7		8
LUMINAIRE	HOOD STYLE	LENS/ELEMENT	LAMP/BALLAST	HOOD FINISH	COLOR	OPTIONS		MOUNTING

1. LUMINAIRE

- SP2 Spectra - Small Scale Housing
- SP2 Spectra LED - Small Scale Housing

2. HOOD STYLE Height: 23.3"/591mm EPA: 1.43

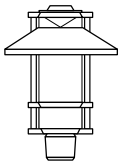
- 

ANG Angled Hood
Dia: 16"/407mm

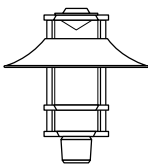

FLR Flared Hood
Dia: 22.5"/572mm

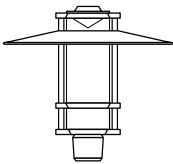

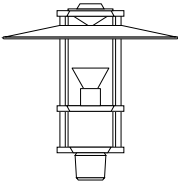
STR Straight Hood
Dia: 23.5"/597mm
- 

IND Indirect
Dia: 23.5"/597mm

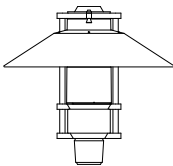

Type 3 Indirect- full cutoff
Dia: 23.5"/597mm

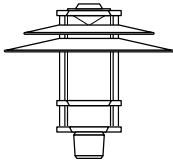

FCO3 Indirect- full cutoff
Dia: 23.5"/597mm

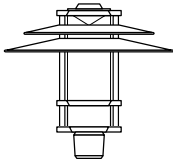

FCO5 Indirect- full cutoff
Dia: 23.5"/597mm

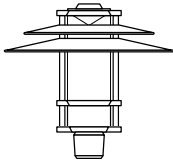

DBL Double Hood
Dia: 23.5"/597mm

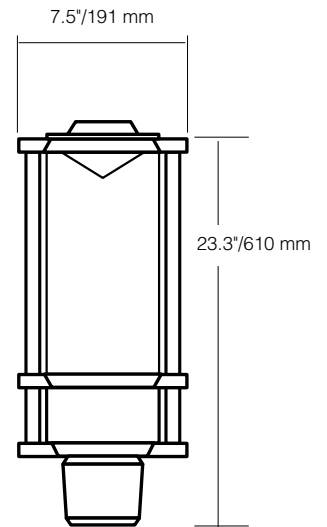

3. LENS /ELEMENT

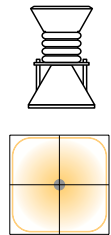
- 

GLA Frosted glass diffuser
Type 5 Light Pattern

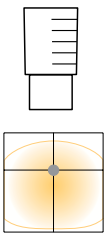

GR3 Glass refractor
Type 3 Light Pattern

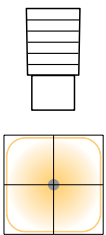

GR5 Glass refractor
Type 5 Light Pattern

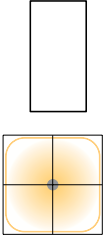

LDL Lightly diffused lens
Type 5 Light Pattern

JOB INFORMATION

TYPE _____

JOB NAME _____

LAMP (BY OTHERS) _____

CUSTOMER _____

DATE _____

Consult factory for any custom/modified products

APPROVALS

1	2	3	4	5	6	7			8
LUMINAIRE	HOOD STYLE	LENS/ELEMENT	LAMP/BALLAST	HOOD FINISH	COLOR	OPTIONS			MOUNTING

4. LAMP/BALLAST

- 18LED-BW 18 LED array. (20.9 total input watts) Bright white (5100K).
120 thru 277 volt. Symmetric distribution.

- 18LED-WW 18 LED array. (20.9 total input watts) Warm white (3500K).
120 thru 277 volt. Symmetric distribution.

- 9LED-BW 9 LED array. (12.2 total input watts) Bright white (5100K).
120 thru 277 volt. Asymmetric distribution.

- 9LED-WW 9 LED array. (12.2 total input watts) Warm white (3500K).
120 thru 277 volt. Asymmetric distribution.

- CF 120 thru 277 electronic ballast for use with 4 pin, 32 or 42 watt
T-4 compact fluorescent lamp.

- 50MH 50 watt metal halide 120/277 volt ballast. Use medium base,
ED-17 lamp.

- 50MHEB 50 watt electronic metal halide 120 thru 277 volt ballast.
Use medium base, ED-17 lamp.

- 70MH 70 watt metal halide 120/208/240/277 volt ballast.
Use medium base, ED-17 lamp.

- 70MHEB 70 watt electronic metal halide 120 thru 277 volt ballast.
Use medium base, ED-17 lamp

- 70MHT6 70 watt metal halide 120/277/347 volt ballast. Use G12 base,
T-6 ceramic lamp

- 70MHT6EB 70 watt electronic metal halide 120 thru 277 volt ballast.
Use G12 base, T-6 ceramic lamp.

- 100MH 100 watt metal halide 120/208/240/277 volt ballast.
Use medium base, ED-17 lamp.

- 100MHEB 100 watt electronic metal halide 120 thru 277 volt ballast.
Use medium base, ED-17 lamp.

- 50HPS 50 watt high pressure sodium 120/277 volt ballast.
Use medium base, ED-17 lamp.

- 70HPS 70 watt high pressure sodium 120/208/240/277 volt ballast.
Use medium base, ED-17 lamp.

- 100HPS 100 watt high pressure sodium 120/208/240/277 volt ballast.
Use medium base, ED-17 lamp.

** All fixtures prewired for 277 volts, unless specified. Lamps not included. All applicable ballasts are EISA compliant.*

JOB INFORMATION

TYPE

JOB NAME

LAMP (BY OTHERS)

CUSTOMER

DATE

*Consult factory for any custom/
modified products*

APPROVALS



1	2	3	4	5	6	7			8
LUMINAIRE	HOOD STYLE	LENS/ELEMENT	LAMP/BALLAST	HOOD FINISH	COLOR	OPTIONS			MOUNTING

5. HOOD FINISH (OPTIONAL)

Hood finish will match luminaire finish unless selecting one of these options

- STS Stainless steel
- COP Natural copper

Hood underside is unfinished to develop a patina.

6. COLOR

- | | |
|--|--|
| <input type="checkbox"/> AWT Arctic White | <input type="checkbox"/> MAL Matte Aluminum |
| <input type="checkbox"/> BLK Black | <input type="checkbox"/> MDG Medium Grey |
| <input type="checkbox"/> MTB Matte Black | <input type="checkbox"/> ATG Antique Green |
| <input type="checkbox"/> DGN Dark Green | <input type="checkbox"/> LGY Light Grey |
| <input type="checkbox"/> DBZ Dark Bronze | <input type="checkbox"/> RAL/
PREMIUM
COLOR |
| <input type="checkbox"/> WRZ Weathered Bronze | <input type="checkbox"/> CUSTOM
COLOR |
| <input type="checkbox"/> BRM Metallic Bronze | <input type="checkbox"/> CUSTOM
COLOR |
| <input type="checkbox"/> VBL Verde Blue | <input type="checkbox"/> CUSTOM
COLOR |
| <input type="checkbox"/> CRT Corten | <input type="checkbox"/> CUSTOM
COLOR |

7. OPTIONS

- 347 347 volt ballast 120/227/347. **Not available with electronic ballast.**
- AD4 Adaptor for SP2. Designed to slip over a 4"/100 mm O.D. pole.
- ULS Upper lens shield in the upper lens area. Provides cutoff optics (1.2% uplight). For indirect models only.
Not available with FCO hood style.
- LDL Lightly diffused lens

JOB INFORMATION
TYPE
JOB NAME
LAMP (BY OTHERS)
CUSTOMER
DATE
<i>Consult factory for any custom/modified products</i>
APPROVALS



1	2	3	4	5	6	7	8
LUMINAIRE	HOOD STYLE	LENS/ELEMENT	LAMP/BALLAST	HOOD FINISH	COLOR	OPTIONS	MOUNTING

8. MOUNTING All arms regardless of hood diameter, have a 4"/100mm distance from the edge of the shade to the pole centerline or face of the wall.

SAP2 Slips over a 4"/100mm pole.

TAP2 slips over a 4"/100mm pole.
B = 4 3/8"/109mm

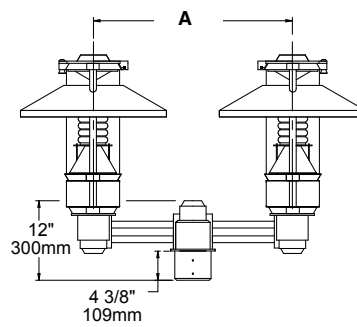
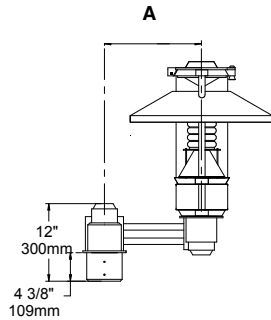

Hood Style	A
Angled (ANG)	12"/300mm
Flared (FLR)	151/4"/381mm
Straight (STR)	153/4"/394mm
Double (DBL)	153/4"/394mm

Hood Style	A
Angled (ANG)	24"/600mm
Flared (FLR)	301/2"/763mm
Straight (STR)	311/2"/788mm
Double (DBL)	311/2"/788mm

AWM2 Wall plate is 8.5"/216mm x 4.75"/120mm

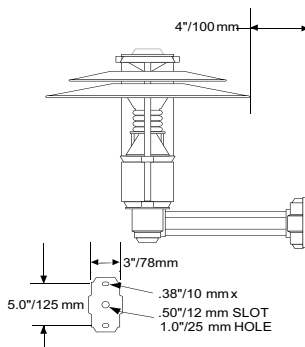

JOB INFORMATION

TYPE

JOB NAME

LAMP (BY OTHERS)

CUSTOMER

DATE

Consult factory for any custom/modified products

APPROVALS

1	2	3	4	5	6	7		8
LUMINAIRE	HOOD STYLE	LENS/ELEMENT	LAMP/BALLAST	HOOD FINISH	COLOR	OPTIONS		MOUNTING

HOUSING

The fixture housing shall be all cast aluminum, A356 alloy, free of any porosity, foreign materials, or cosmetic fillers. The ballast shall be mounted internally and accessed by loosening two captive bolts and lifting off the top of the fixture. The top cover shall be hinged and secured with one captive tool-less fastener for relamping. The top shall seal with a molded silicone gasket. The upper reflector cone shall be matte finished anodized aluminum. The lens shall be clear seamless acrylic sealed to the housing with a molded silicone gasket on the top and bottom. The vertical struts shall be 316 stainless steel tubing. All internal and external hardware shall be stainless steel. All female threads on the aluminum parts shall be cast-in-place brass inserts to ensure no thread seizure.

HOOD

The hoods shall be spun from 6061 T-6 aluminum, 316 stainless steel or 110 copper. The shade shall have hemmed or beaded edges for added strength. The underside of the painted shades and all indirect shades (of aluminum, stainless steel or copper) shall be painted a high reflectance white. Stainless steel and copper shade shall be unfinished on both sides, except for the indirect (IND) models. Stainless steel hood not available with FCO model

LENSES/ELEMENTS

All lenses shall be molded, seamless high impact lighting grade acrylic.

The GLA element shall be frosted borosilicate glass with a twist on connection to the lower cone assembly. The cone shall be matte finished anodized aluminum.

The GR3 and GR5 shall be precision molded borosilicate glass refractors with the Type 3 or Type 5 distribution. The refractors shall be mounted to a gasketed aluminum holder with an internal pressure plate.

The LDL lens shall be acrylic with a lightly diffused internal finish.

The IND indirect fixtures shall have a clear acrylic lens with a lower reflector cone and an upper diffusing cone.

The one-piece hood and lens shield provides IES full cutoff classification meaning there is zero light emitted above 90° horizontal. The lens shield is aluminum and painted to match the fixture color (IND-FCO only.)

ELECTRICAL

The ballast shall be integral to the fixture, mounted on a prewired module with a quick disconnect plug. The ballast module shall have keyhole slots and be removable by loosening two screws. Sockets shall be pulse rated porcelain. HID ballasts shall be high power factor, rate for -30°C starting. The compact fluorescent ballast shall be electronic for use with 4 pin lamps (GX24q-4 socket) rated for -18°C starting temperature.

FINISH

Fixture finish shall consist of a five stage pretreatment regimen with a polymer primer sealer, oven dry off, and top coated with a thermoset super TGIC polyester powder coat finish. The finish shall meet the AAMA 605.2 performance specification which includes passing a 3000 hour salt spray test for corrosion resistance.

ARM and POLE MOUNTING

The pole mounted arm for a single fixture (SAP) and pole mounted arm for two fixtures at 180° (TAP) shall have a cast aluminum post top and fixture fitter with two round horizontal stainless steel bars. The post fitter shall slip over a 3"/75mm pole and be secured with six stainless steel set screws. The wall mounted arms for a SP2 fixture shall have a cast aluminum wall plate, cover and fixture fitter with two round horizontal stainless steel bars. The cover shall secure to the wall plate with four stainless steel set screws.

CERTIFICATION

Fixtures shall be listed with ETL for outdoor, wet location use, UL1598 and Canadian CSA Std. C22.2 no.250. IP=65.

WARRANTY **5 YEAR WARRANTY**

Spectra LED, including housing, LEDs and electrical components, is warranted for five years. Non LED fixture is warranted for three years. Ballast components carry the ballast manufacturer's limited warranty. Any unauthorized return, repair, replacement or modification of the Product(s) shall void this warranty. This warranty applies only to the use of the Product(s) as intended by AAL and does not cover any misapplication or misuse of said Product(s), or installation in hazardous or corrosive environments.

AAL reserves the right to change product specifications without notice.

Specifications



JOB INFORMATION

TYPE

JOB NAME

LAMP (BY OTHERS)

CUSTOMER

DATE

Consult factory for any custom/modified products

APPROVALS

