

TRA 2M

Weight: 7 LBS. EPA: .62

The arm shall be one piece cast aluminum construction. The arm shall be prewired with a quick connector for easy installation.

The arm shall have a cast aluminum fitter welded to the top of the arm(s) for attaching the fixture. The fixture shall be mounted with three stainless steel bolts through the top of the arm fitter into the fixture. The attachment point shall have a silicone pad for sealing the fixture to arm connection.

The arm shall bolt to a 4"/100MM diameter pole.

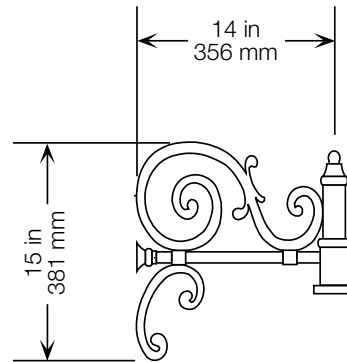

SOLD TO	PO #	JOB NAME
/	/	/

APPROVALS

Architectural Area Lighting

16555 East Gale Ave. | City of Industry | CA 91745
P 626.968.5666 | F 626.369.2695 | www.aal.net
Design patents, Copyright © 2010 Rev 01/2010

TRA 2L

Weight: 9 LBS. EPA: .75

The arm shall be one piece cast aluminum construction. The arm shall be prewired with a quick connector for easy installation.

The arm shall have a cast aluminum fitter welded to the top of the arm(s) for attaching the fixture. The fixture shall be mounted with three stainless steel bolts through the top of the arm fitter into the fixture. The attachment point shall have a silicone pad for sealing the fixture to arm connection.

The arm shall bolt to a 4"/100mm diameter pole.

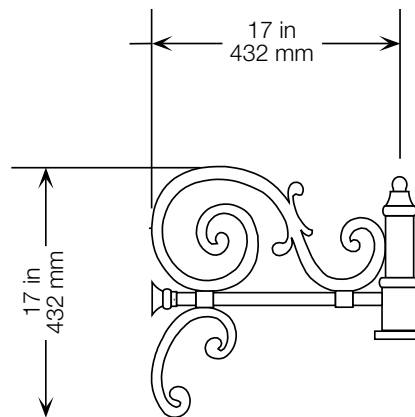

SOLD TO	PO #	JOB NAME
/	/	/

APPROVALS

Architectural Area Lighting

16555 East Gale Ave. | City of Industry | CA 91745
P 626.968.5666 | F 626.369.2695 | www.aal.net
Design patents, Copyright © 2010 Rev 01/2010